

Prepared by  
Tung Wah College  
Library

AY 2025/2026

LIBRARY

HANDBOOK



東華學院  
TUNG WAH COLLEGE

# Contents

<b>1 - Introduction</b> .....	<b>1</b>
1.1 - Mission	1
1.2 - Key Information	1
<b>2 - Opening Hours</b> .....	<b>2</b>
<b>3 - Collections</b> .....	<b>3</b>
3.1 - Classification of Resources	4
3.2 - Circulation Collection	7
3.3 - Reference	7
3.4 - Reserve	7
3.5 - Teaching Resources Collection	7
3.6 - Multimedia	7
3.7 - Career Collection	8
3.8 - National Security Education Collection	8
3.9 - Education Resources	8
3.10 - Periodicals	8
3.11 - Electronic Resources	9
3.12 - Location of Library Collections	10
<b>4 - Floor Plan</b> .....	<b>11</b>
<b>5 - Lending Services</b> .....	<b>13</b>
5.1 - Borrowing	13
5.2 - Hold Request	14
5.3 - Recall	14
5.4 - Returning	14
5.5 - Book Drop Service	15
5.6 - Charge for Loss and Damage	17
5.7 - Assumed Lost	17
5.8 - Circulation Notices	18
5.9 - Suspension of Borrowing Rights	18
5.10 - Interlibrary Loan (ILL) Service	18
<b>6 - User Services</b> .....	<b>19</b>
6.1 - Library Orientation	19
6.2 - Library Workshop	19
6.3 - Information Service	19
6.4 - WhatsApp-the-Library	19
6.5 - Zoom-a-librarian	19
6.6 - Access to Other Libraries	20
6.7 - Support for Students with Special Needs	20

# Contents

(Cont'd)

<b>7 - Other Services</b> .....	<b>21</b>
7.1 - Wi-Fi Access	21
7.2 - Learning Laboratory	21
7.3 - Discussion Room	21
7.4 - Audio-visual (AV) Room	22
7.5 - Quiet Study Room and Study Carrels	22
7.6 - Photocopying and Printing	22
7.7 - Book Sterilizer	23
7.8 - Digital Equipment Borrowing Services	23
<b>8 - Contact Us</b> .....	<b>24</b>

# 1 Introduction

## 1.1 Mission

The mission of the Library is to build, maintain and provide quality resources and the most effective library services possible in support of the learning, teaching and research activities of the College.

## 1.2 Key Information

The Library is located on the fifth and sixth floors (5-6/F) of the Ma Kam Chan Memorial Building (King's Park Campus). Users can enter the Library through the entrance on the 5/F. It also has a Resources Center at the Kwai Hing Campus. General enquiry service as well as IT and photocopying support are available throughout opening hours. The Circulation Counter provides circulation service until 30 minutes before the Library closes.

Updated information about library services and facilities as well as various electronic resources is available on the library website. (<https://www.twc.edu.hk/library>)

[TWC Search](#) is a one-stop search engine for accessing the majority of library resources. Through this platform, users can explore e-books and electronic resources, check the status of physical items, view their current circulation records, and renew loans.

The Library Regulations are readily available at the [Library website](#). All Library users should familiarise themselves with the regulations. Ignorance of any clause will not be accepted as an excuse for breach of the Library Regulations.

The [Guides & Tutorials](#) page of the library website provides quick reference for easy navigation of library resources and collections.

# 2 Opening Hours

## King' Park Campus

	Semester 1 & 2	Semester 3
Monday - Friday	8:30 am - 9:00 pm	8:30 am - 7:00 pm
Saturday	10:00 am - 6:00 pm	Closed
Sunday & Public Holiday	Closed	Closed

	Semester Break
Monday - Friday	9:00 am - 6:00 pm
Saturday	Closed
Sunday & Public Holiday	Closed

## Kwai Hing Campus

	Semester 1 & 2	Semester 3
Monday - Friday	9:00 am - 6:00 pm	9:00 am - 6:00 pm
Saturday, Sunday & Public Holiday	Closed	Closed

	Semester Break
Monday - Friday	9:00 am - 6:00 pm
Saturday, Sunday & Public Holiday	Closed

During the Examination period, the Library at the King's Park Campus will also open on **Sunday (10:00am - 6:00 pm)**.

Details of special opening hours will be announced online in advance and posted at Library entrance. Special opening arrangement during adverse weather (typhoon or rainstorm) is viewable via the quick link "[Opening Hours](#)" on the Library Homepage.

Please pay attention to the following for the latest information:

- the "**News & Events**" section of the **Library website**; or
- Library's **Facebook** Page, **Instagram** and **WeChat Moment**

# 3 Collections

The Library aims to build a collection that caters to the current and emerging needs in learning, teaching and personal development of College students and staff.

Relevant and appropriate resources that support the teaching of the academic programmes are core elements to empower authentic learning and knowledge building in an academic institution. Essential print publications, periodicals, audio-visual materials and electronic resources are carefully selected and acquired.

Most items in the Library collection (reserve items, general books and multimedia materials) are available for borrowing. Some items, such as reference titles and periodicals, may only be used in the Library. This ensures the availability of most needed items to as many users as possible.



### 3.1 Classification of Resources (Cont'd)

Resources in the TWC Library are classified using the Library of Congress (LC) Classification Scheme, and are shelved accordingly.

The following is an outline of the main subject divisions of the Library of Congress Classification Scheme:

Class		Subjects
<b>A</b>		<b>GENERAL WORKS</b>
<b>B</b>		<b>PHILOSOPHY. PSYCHOLOGY. RELIGION</b>
BF	1 - 990	Psychology
<b>C</b>		<b>AUXILIARY SCIENCES OF HISTORY</b>
<b>D</b>		<b>HISTORY (OTHER THAN AMERICAN)</b>
DS	701 - 799	History of China
<b>E-F</b>		<b>HISTORY OF THE AMERICAS</b>
<b>G</b>		<b>GEOGRAPHY. ANTHROPOLOGY. RECREATION</b>
<b>H</b>		<b>SOCIAL SCIENCES</b>
HA		Statistics
HB		Economic Theory
HC		Economic History and Conditions: National Production and Economic Conditions by Country; Environmental Policy
HD		Economic History and Conditions by Industry; Labor
	60 - 60.5	Social responsibility of business. Social entrepreneurship
HE		Transportation and Communication
HF		Commerce, Business and Management including Accountancy and Industrial Psychology
HG		Finance including: Money, Banking, Investment, Insurance

<b>Class</b>	<b>Subjects</b>
<b>H</b>	<b>SOCIAL SCIENCES</b>
HJ	Public Finance including Taxation
HM	Sociology
HN	Social History and Conditions, Social Problems, Social Reform
HQ	Social Groups: Family, Marriage, Woman, Child Development
1060 -1064	Gerontology (Social aspects)
HV	Social Pathology, Social and Public Welfare, Criminology
8073-8079.35	Investigation of crimes. Forensic Science
<b>J</b>	<b>POLITICS AND GOVERNMENT</b>
<b>K</b>	<b>LAW</b>
<b>L</b>	<b>EDUCATION</b>
LB	Theory and Practice of Education: Teaching, Teacher Training, School Administration and Organization, Education Psychology
1139.2-1139.5	Early Childhood Education
LC	Special Education
<b>M</b>	<b>MUSIC</b>
<b>N</b>	<b>FINE ARTS</b>
NC	Drawing, Design, Illustration, Commercial Arts, Graphics
<b>P</b>	<b>LANGUAGE &amp; LITERATURE</b>
PE	English Language and Literature
PL	Oriental Language and Literatures
PN	Literature (General)
1997	Feature Films

<b>Class</b>	<b>Subjects</b>
<b>Q</b>	<b>SCIENCE (GENERAL)</b>
QD	Chemistry
QH	Natural History. Biology, Genetics, Ecology
QP	Physiology
QM	Human Anatomy
QR	Microbiology
<b>R</b>	<b>MEDICINE (GENERAL)</b>
858 - 859.9	Medical Informatics
895 - 950	Medical Radiology
RA	Public Aspects of Medicine: Medicine and the State, Public Health, Environmental Health
971 - 976	Health Administration
RB	Pathology including Medical Laboratory Technique
RC	Internal Medicine including Neurology, Psychiatry, Geriatrics, Industrial Medicine, Radiography and Radiation Therapy
78 - 79.6	Radiology
RD	Surgery
RG	Gynecology and Obstetrics
RJ	Pediatrics
RM	Therapeutics. Pharmacology
695-894	Physiotherapy and Occupational Therapy
RS	Pharmacy and Materia Medica
RT	Nursing
<b>S</b>	<b>AGRICULTURE (GENERAL)</b>
SF	Animal Culture
<b>T</b>	<b>TECHNOLOGY</b>
<b>U</b>	<b>MILITARY SCIENCE</b>
<b>V</b>	<b>NAVAL SCIENCE</b>
<b>Z</b>	<b>BIBLIOGRAPHY, LIBRARY SCIENCE. INFORMATION RESOURCES (GENERAL)</b>

### **3.2 Circulation Collection**

This collection consists of books, mainly written in English and Chinese, which are available for loans.

### **3.3 Reference**

This collection contains tools to help users in their research, study and current information needs. The tools tend to be sources of specific factual data and information. These handy tools include dictionaries, encyclopedias, guidebooks, handbooks, directories, etc.

Reference items are for **on-site reading** only.

### **3.4 Reserve**

Reserve Collection is a collection purposefully selected by the academic staff to ensure student learning is well-supported by the latest and most appropriate materials. It includes essential texts, articles, audio-visual materials, which are available for loan(s).

### **3.5 Teaching Resources Collection**

The Teaching Resources Collection is exclusively available to full-time academic staff. This collection comprises printed and electronic books specifically curated to support teachers in course preparation.

### **3.6 Multimedia**

The Multimedia collection comprises audio-visual materials in a wide range of subjects. Formats available within the Library include videodiscs (VCD), digital versatile discs (DVD), and compact audio discs (CD). These materials can be checked out at the Circulation Counter.

### **3.7 Career Collection**

This collection consists of books on writing resumes and cover letters, preparing for interviews, job hunting, and choosing and preparing for a career. These items are available for loan and follow the same loan rules and quotas as the Circulation Collection.

### **3.8 National Security Education Collection**

This collection consists of books about national security and Basic Law. These items are available for loan and follow the same loan rules and quotas as the Circulation Collection.

### **3.9 Education Resources**

To support the Education programmes offered by TWC, this collection comprises juvenile literature and children's books in English and Chinese. These items are available for loan and follow the same loan rules and quotas as the Circulation Collection.

### **3.10 Periodicals**

The Library subscribes to periodicals, including scholarly journals, professional and trade journals, general interest and popular magazines, as well as newspapers that cover a diversity of topics.

Some titles are in print format while the majority are in electronic format, i.e. e-journals.

To view or search within the list of key e-journal titles in one go, please click [Journal Search](#) in TWC Search for details.

### 3.11 **Electronic Resources**

The Library provides access to various databases covering subjects relevant to the College's curriculum as well as news databases covering newspapers and magazines published in Hong Kong and nearby regions in Greater China.

Other electronic resources include e-books, e-journals, and online English Learning programmes. Users can access these electronic resources anytime via the Library website. While accessing e-resources remotely, users need to input their College email login and password for authentication.

The list of Electronic Resources is viewable via this Library webpage "[E-Resources](#)". Moreover, individual resource or database is also searchable via TWC Search.

### 3.12 Location of Library Collections

#### King's Park Campus

Library Collection	Location
Closed Stack	5/F Counter
Special Collection	
Career Collection	5/F
National Security Education Collection	
Circulation Collection (Call no. A-K, PN-PZ)	
TWC Institutional Repository	
Multimedia	
Newspaper & Magazines (Current Issues)	
Reference	
Reserve	
Circulation Collection (Call no. L-PM, Q-Z)	6/F
Education Resources	
Oversize Books	
Magazines & Periodicals (Back Issues)	

#### Kwai Hing Campus

Library Collection	Location
Circulation	Book Shelf
Reference	
Reserve	

# 4 Floor Plan

## King's Park Campus

5/F

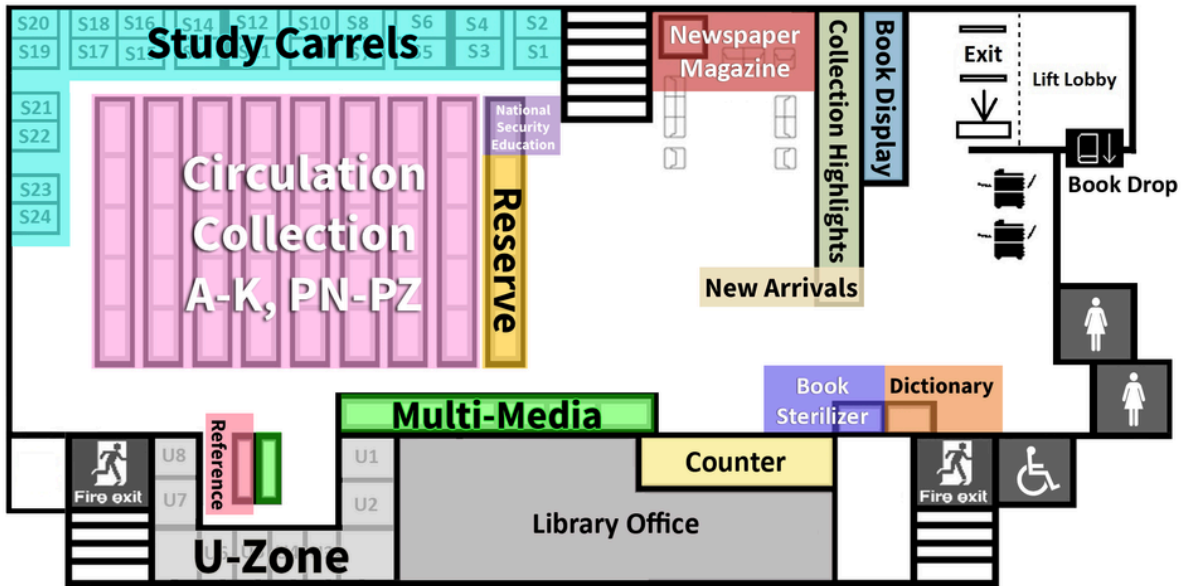

6/F

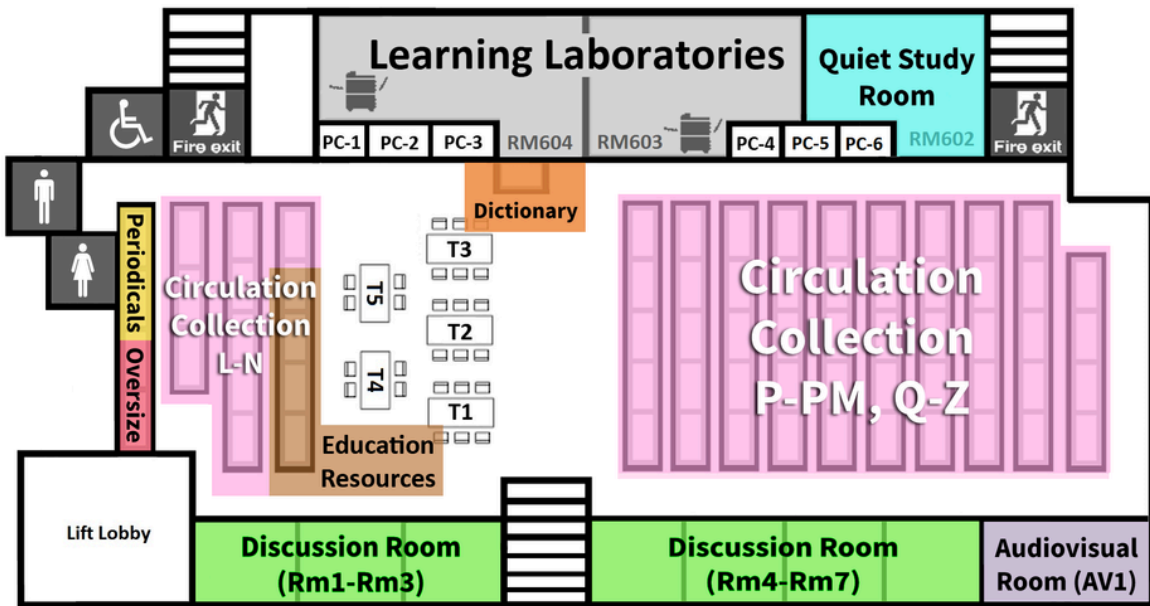

## Kwai Hing Campus

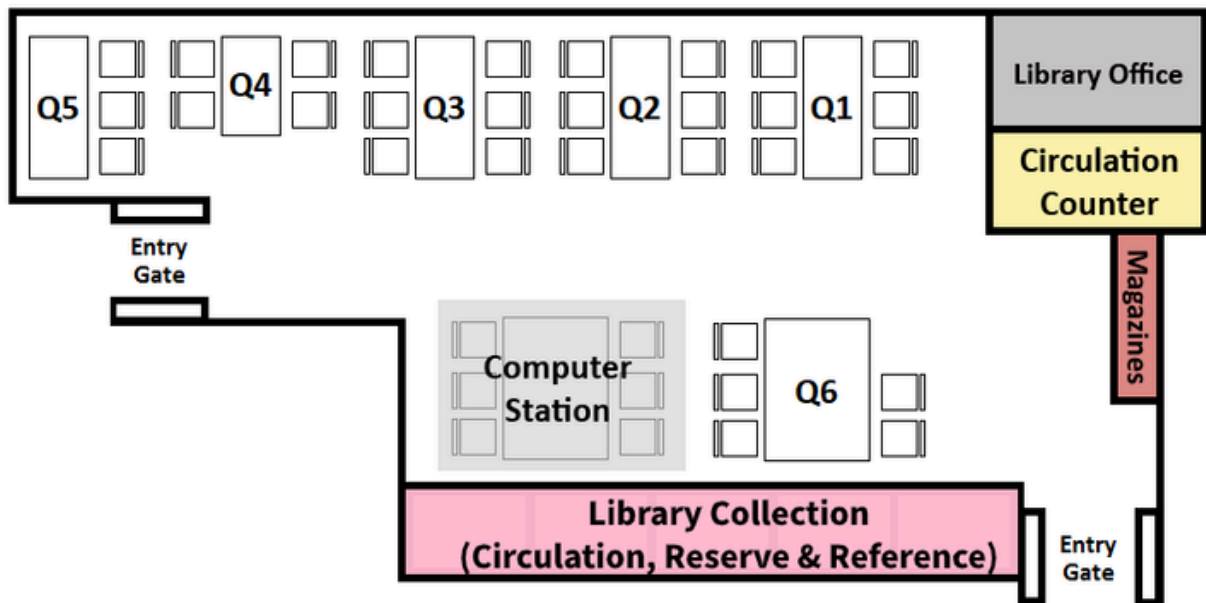

# 5 Lending Services

Lending services are available at the Circulation Counter **until 30 minutes before the Library closes.**

## 5.1 **Borrowing**

TWC users may borrow library materials with a valid College ID card. All Library materials must be checked out at the Circulation Counter properly. There may be disciplinary action against any users who removes library materials from the Library without proper checkout or authorization.

### **Loan Privileges for Students / Part-time Academic Staff /**

### **Full-time Non-academic General Rank Staff / Part-time Research Staff**

Material Type	Loan Quota	Loan Period	Maximum Loan Period	Overdue Fine *	Request Limit
Circulation Item	50 items	30 days	150 days	HK\$2 per day per item	10 items
Multimedia Item	10 items	7 days	14 days		HK\$20 per day per item
Digital Equipment	5 items	Before library closing for the day			
Reserve Item (3 Days)	10 items	3 days			
Reserve Item (7 Days)		7 days			
<b>Overall Total</b>	<b>50 items</b>				

\* Holiday Exclusive

**Loan Privileges for Full-time Academic Staff / Full-time Research Staff / Non-academic Senior Rank Staff:**

Material Type	Loan Quota	Loan Period	Maximum Loan Period	Overdue Fine *	Request Limit
Circulation Item	80 items	90 days	360 days	HK\$2 per day per item	10 items
Multimedia Item	10 items	7 days	14 days		Nil
Digital Equipment	5 items	Before library closing for the day			
Reserve Item (3 Days)	10 items	3 days		HK\$20 per day per item	
Reserve Item (7 Days)		7 days			
<b>Overall Total</b>	<b>80 items</b>				

\* Holiday Exclusive

## 5.2 **Hold Request**

User can request loaned items from Circulation Collection via TWC Search. An email notice will be sent to alert the user when the item is ready to be picked up. Requested items will be released after the last pick-up date indicated in the email notice.

## 5.3 **Recall**

Books on loan to borrower may be "recalled" back to the Library when they are requested by other borrowers. It may lead to a recall of the checked out items and may shorten their due date, i.e. 14 days from the date of recall. Late return of recalled items will incur an overdue fine of HK\$4 per item per day.

## 5.4 **Returning**

Users are reminded to return loan item to the Circulation Counter or the Book Drops (on 5/F and Foyer at G/F) at King's Park Campus, 1/F lift lobby of Cheung Chin Lan Hong Building (Tower B) at Mongkok Campus, near the entrance of 1608A at Kwai Hing Campus and 6/F at Tsim Sha Tsui Campus on or before the due date.

## 5.5 Book Drop Service (Cont'd)

Book drops can be found at the following locations in King's Park, Mongkok, Kwai Hing and Tsim Sha Tsui Campuses:

### King's Park Campus

#### 5/F Lift Lobby

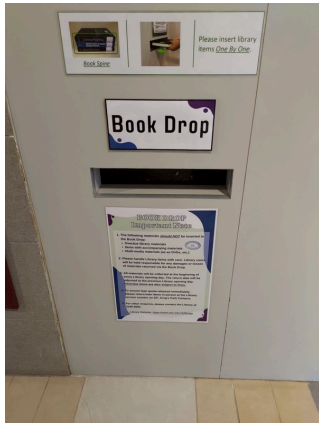

#### G/F Foyer

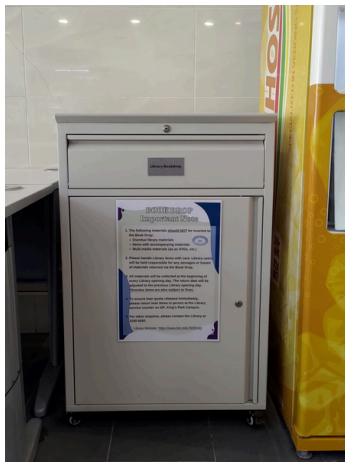

## Mongkok Campus

### 1/F Lift Lobby of Tower B

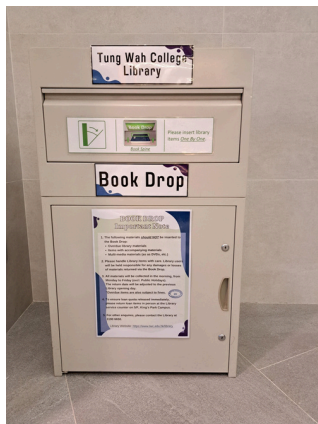

## Kwai Hing Campus

### Near the entrance of 1608A

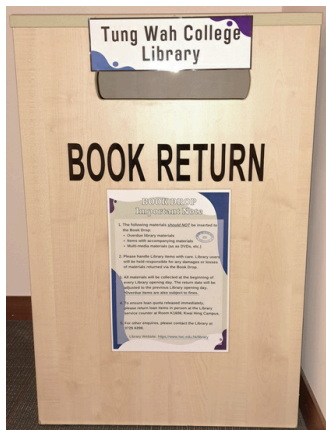

## Tsim Sha Tsui Campus

### Near the entrance of 6/F Lift Lobby

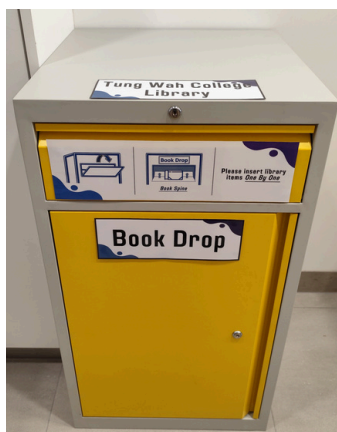

Please return your books on or before the due date to avoid overdue fines. Late return is subject to a fine according to the Library Regulations.

The following types of materials cannot be placed in book drops and must be **returned to the Library at Circulation Counter:**

- Overdue library materials;
- Items with accompanying materials;
- Multimedia materials (such as DVDs, etc.);
- Digital Equipment; and
- Reader cards from other libraries.

Please handle library books with care when using the book drop. The library will not be responsible for damages or loss of materials in book drops.

#### **5.6 Charge for Loss and Damage**

Loss or damage of loan items should be reported to the Library as soon as possible. A charge for lost/damaged library materials will be imposed.

The charge is calculated based on **the replacement cost of the lost/damaged item plus a processing fee of HK\$60 and any accumulated fine.** All lost/damaged items remain the property of Library. **All sums paid are non-refundable.**

#### **5.7 Assumed Lost**

A loaned item that overdue for 90 days is assumed lost. The borrower will be billed accordingly and his/her borrowing privileges will be suspended.

The charge is calculated based on **the replacement cost of the lost item, a processing fee of HK\$60 and the maximum overdue fine.** All assumed lost items remain property of the Library. **All sums paid are non-refundable.**

## 5.8 Circulation Notices

All library notices, including overdue notices and hold pick-up notices, will be sent to user's TWC email account as a courtesy. **Failure to read or receive an email notice does not relieve the borrower from responsibility for overdue items or resulting fines.**

## 5.9 Suspension of Borrowing Rights

Suspension of borrowing rights may be applied to user with any of the following conditions:

- Six or more overdue loan items;
- Loan item overdue for 60 days or above;
- Total library fine exceeds HK\$100

## 5.10 Interlibrary Loan (ILL) Service

Interlibrary Loan Service is a research-support service, which helps our eligible users to obtain books or journal articles not available from TWC Library subscription. Please visit this library webpage "[Interlibrary Loan \(ILL\) Service](#)" for latest user instructions.

# 6 User Services

## 6.1 Library Orientation

At the beginning of each academic year, students can sign up for library orientation to know more about the library resources and services as well as the library staff who will offer guidance for information search and learning.

## 6.2 Library Workshop

Information skills workshops are organized throughout the academic year. These workshops cover many different topics, such as effective and efficient searching in the Library Catalogue and databases, as well as information search skills for assignments.

## 6.3 Information Service

Information enquiry service is offered at the Circulation Counter. Professional library staff are also available to assist users with research and information needs. Students are welcome to seek advice on how to begin a project or an assignment using a variety of information resources.

## 6.4 WhatsApp-the-Library

WhatsApp-the-Library offers quick feedback and assistance during library opening hours. This service is available from 9:30 am to 5:30 pm (Mon - Fri, excluding Public Holidays). Enquiry received after 5:30 pm will be responded next service day.



## 6.5 Zoom-a-librarian

Zoom-a-librarian offers users have meeting and chat with our librarian to get immediate help on using library resources for learning and teaching. Please visit this library webpage "[Zoom-a-librarian](#)" for details.



## **6.6 Access to Other Libraries**

Reader cards for onsite readership at partner libraries are available for loan at the Circulation Counter. User may borrow a card for up to 7 days each time. The regulations of the respective libraries should be followed.

For details of the partner libraries, please visit this library webpage "[Access to other libraries](#)".

## **6.7 Support for Students with Special Needs**

Please visit this library webpage "[Students with Special Needs](#)" for details.

# 7 Other Services

## 7.1 Wi-Fi Access

The wireless network connection is available throughout the campus. Users are encouraged to access learning resources provided by the Library via the Internet with their notebook computers or other handheld devices anytime.

The Wi-Fi setup guide can be found at this ITSO webpage "[Help & Support - Wi-Fi](#)".

## 7.2 Learning Laboratory

Two Learning Laboratories are located on the 6/F of the Library. These learning laboratories are equipped with computers for learning and research purposes. Users are encouraged to make use of the space and technologies provided to extend learning beyond textbooks and printed media. No booking is required for seating.

Users are advised to read the [Acceptable Use Policy](#) (AUP) (that applies to all IT facilities on campus) and comply with [Laboratory Official Rules](#), adopted by the Information Technology Services Office (ITSO).

## 7.3 Discussion Room

Seven Discussion Rooms are located on the 6/F of the Library of King's Park Campus. Each discussion room is equipped with an all-in-one computer and whiteboard to facilitate students' discussion and group work.

Reservation of these rooms requires a minimum of 2 users. The Discussion Rooms can be booked via the Online Room Booking System at <https://rbs.twc.edu.hk>.

#### 7.4 **Audio-visual (AV) Room**

To facilitate students' learning with the multimedia resources, one AV Room with 55-inch LED TV and Blu-ray player are located on the 6/F of the King's Park Campus.

Reservation of these rooms requires a minimum of 2 users. The AV Rooms can be booked at <https://rbs.twc.edu.hk>.

#### 7.5 **Quiet Study Room and Study Carrels**

Quiet, individual study spaces are available on both 5/F and 6/F (Quiet Study Room) of the King's Park Campus. Please be considerate and keep your voice low. No group discussion is allowed.

#### 7.6 **Photocopying and Printing**

Photocopying and printing services are available at the following locations:

Type of Machine	Payment Method	Location
<b>Multi-functional Photocopier</b>	Octopus	Available on 5/F & 6/F at the King's Park Campus

Charging Rates:

Paper Size	Colour	Charge per page
<b>A4</b>	Black & White	HK\$0.3
	Colour	HK\$1.5
<b>A3</b>	Black & White	HK\$0.6
	Colour	HK\$3.0

When making print copies or photocopies, **users are reminded to observe the copyright restrictions.** Failure to do so may result in serious consequences.

The Copyright Ordinance of Hong Kong is available online at <https://www.elegislation.gov.hk/hk/cap528>.

## 7.7 Book Sterilizer

A self-service ultraviolet (UV) book sterilizer is available in the Library (located next to KPC Circulation Counter). Users are welcome to use the device to sterilize library books, up to 6 regular-sized books can be placed inside the sterilizer at one time for sterilization (each process last around 50 seconds).

## 7.8 Digital Equipment Borrowing Services

The Library provides charging cable, AC adapter and earphone borrowing services at the Circulation Counter. All borrowed equipment is to be used within the Library only and must be returned within 30 minutes before the Library closes at Circulation Counter.



# 8 Contact Us

All enquiries can be made in person at the Circulation Counter or directed to:



3190-6650 (King's Park Campus)  
3725-6208 (Kwai Hing Campus)



5575-1564  
(9:30 am - 5:30 pm, Mon to Fri, excl. Public Holidays)



**Email**      [lb@twc.edu.hk](mailto:lb@twc.edu.hk)



**Facebook**      [Tung Wah College Library - 東華學院圖書館](#)



**Instagram**      [@tungwahcollegelibrary](#)



**Follow us on Facebook & Instagram to  
get the latest news !!!**

# TUNG WAH COLLEGE

## LIBRARY



東華學院  
馬錦燦紀念大樓

馬清偉題